



BEYOND
CORONA
Enabling Life



We value
your health

ENCEE CHLOR TUNNEL

Disinfection Tunnels to Fight Against COVID-19



Disinfects vehicles
in minutes



Reduces disinfection
costs by 100%



Reduces the impact
of disinfection on the
environment



Enables disinfectant
production with the
on-site generator

ENCEE Chlor Tunnel is a disinfectant tunnel with an auto-spray system. It has an in-built sensor equipped with an atomizing system, a control system, a pump, and high-pressure pipes & valves. It disinfects the whole vehicle within a few minutes.

We offer three variants to the disinfection tunnels:



ENCEE Way

ENCEE Way is a vehicle disinfection solution provided to decontaminate vehicles and equipment entering the premises. A high-pressure spray system effectively saturates the environment, penetrating the driver compartment and decontaminating all surfaces

ENCEE Walk

ENCEE Walk is a disinfection solution for building entrances that makes sterilizes groups of people together. The closed compartment with high-pressure sprays effectively kills any virus the people might have been exposed to. The tunnel sensors detect movement of people and auto activates spray for disinfection to kill viruses found on clothes and exposed body parts



ENCEE Booth

ENCEE Booth is a cost effective disinfection solution for sanitizing people individually. Installed at entrances, this booth enables full-body disinfection of people in a closed booth through high-pressure spray system that sprays highly effectively disinfectants to kill viruses found on clothes and exposed body parts

Onsite Sanitizer Generator:

The tunnel has an on-site sanitizer generator which produces 100 L of the disinfectant solution in 8 hours.

Key Reaction that generates the Disinfectant:



Working Principle:

The tunnel is equipped with internal atomizing nozzles that saturate the environment with a disinfectant solution. The system is connected to a control system capable of automatically mixing the sanitizing product. It also has a motion sensor that detects the vehicle when it enters the tunnel.



Benefits:

- Ideal for people working in **close proximity or groups**
- It disinfectants a person in **5 seconds** and costs **2 paisa/person**
- It has an **on-site sanitizer generator** with a tank volume of 100 litres
- It is an **auto-spray system** with an **in-built motion sensor**
- It is an **economical and sustainable** solution

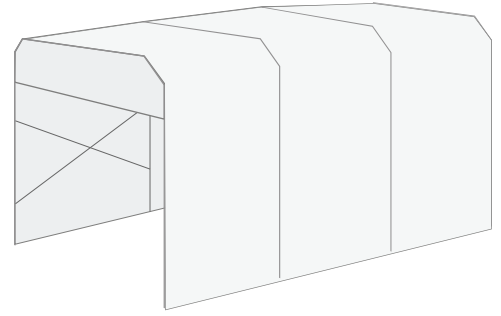

Specifications:

- Structure is made of MSEP / PUF
- Wall cladding with PVC Cover / ACP / PUF/ Polycarbonate sheet cladding
- The sensor operated sprayer and mist fogging system for the spray of disinfectant with a high-pressure pump
- Power Requirement – Single Phase
- 100 Ltr LDPE/FRP tank capacity for the disinfectant solution.
- ENCEE CHLOR Hypo Onsite generator (Optional)

Applications:

It can be used in public places like,



Hospitals



Public Transport



Factories



Educational Institutions



Markets



Office Complexes



Shopping Malls



Cinema Halls

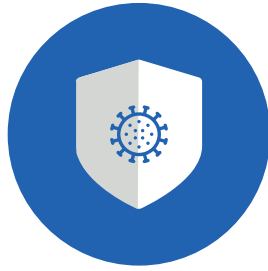

BEYOND

CORONA

Enabling Life

www.beyondcorona.in

Get in Touch with us,

We have over 15 years of experience in providing disinfectant and water treatment solutions for urban and rural areas across India.



We value
your health

Email: beyondcorona@ritewater.in | **Website:** www.ritewater.in

Contact: +91 798 1290216